



CHRISTCHURCH CITY COUNCIL

2008 LIDAR SURVEY

VOLUME 11261B01NOP

Summary

Project

AAMHatch has been engaged by Christchurch City Council to provide digital terrain data from Airborne Laser Scanning (ALS) for the Environment Canterbury LiDAR Survey. To this end, ALS data was acquired from a fixed wing aircraft between February 6th and 11th 2008.

Data

The data provided in this volume contains:

- All data in 2km x 2km tiles
- Filtered ground strikes (ENH)/(X,Y,Z) in space delimited ASCII
- All unthinned laser strikes (E,N,H,I)/(X,Y,X,I) in space delimited ASCII (NZGD49/NZMG, Lyttelton 1937 MSL);
- Date time stamped trajectories in ASCII and ESRI shp formats (NZGD49/NZMG, ellipsoidal height).
- Geoid Model used in DXF format

1. Project Report.....	3
2. Data Installation	5
3. Additional Services	7
4. Metadata.....	8
5. Conditions Of Supply	10
6. Validation Plots.....	11
7. Files Supplied	12

1. PROJECT REPORT

Acquisition: Airborne Laser Scanning (ALS) data was acquired from a fixed wing aircraft between February 06th and 11th 2008.

Ground Support: GPS base station support was provided by Eliot Sinclair & Partners Limited on 02/06/08. The ground check points acquired by the Surveyor for Christchurch City Council allowed an assessment of the accuracy of the ALS data. A summary of the results of the checkpoint analysis is provided in the *Data Validation* section of this document. Delays in receiving field data and coordinates in the requested formats were encountered.

Data Processing: Reduction of the ALS data proceeded without any significant problems. Laser strikes were classified into ground and non-ground points using a single algorithm across the project area. ALS strikes on water bodies have been omitted from the dataset. The quality of the terrain model was further improved by manual checking and editing of the ALS data classifications using intensity imagery.

Further Processing: The data has been thinned to remove superfluous points without detracting from the terrain definition.

Data Presentation: The data provided on this volume has been supplied in accordance with a specification agreed with the primary client. Subsequent users experiencing difficulties in handling the data should please contact AAMHatch to arrange a more appropriate data presentation.

Geoid: Data supplied by Eliot Sinclair & Partners Limited adopts the NZGeoid05 and the Vertical Adjustment Parameters, indicated in the GPS Calibration Report (20/05/2008) and the Survey Report (ref:290335 21/05/2008). These do not reflect true paired coordinates of ellipsoidal and spirit levelled heights. Analysis of data confirms this is correct.

In the supplied GPS Calibration Report (20/05/2008) section: Vertical Adjustment Parameters are provided as follows:

Easting coordinate of origin point 381658.340m (NZGD2000, Mount Pleasant 2000)
Northing coordinate of origin point 804914.304m (NZGD2000, Mount Pleasant 2000)
Vertical separation at origin 0.257m
Slope east 2.177ppm
Slope north -4.041ppm

The difference between orthometric and ellipsoidal heights for provided control points and NZgeoid05 yield approximately the same parameters:

Slope east 2.2 ppm
Slope north -4.0 ppm

The correction surface, computed based on provided parameter, and the difference between NZgeoid05 and control points (contours) are depicted below.

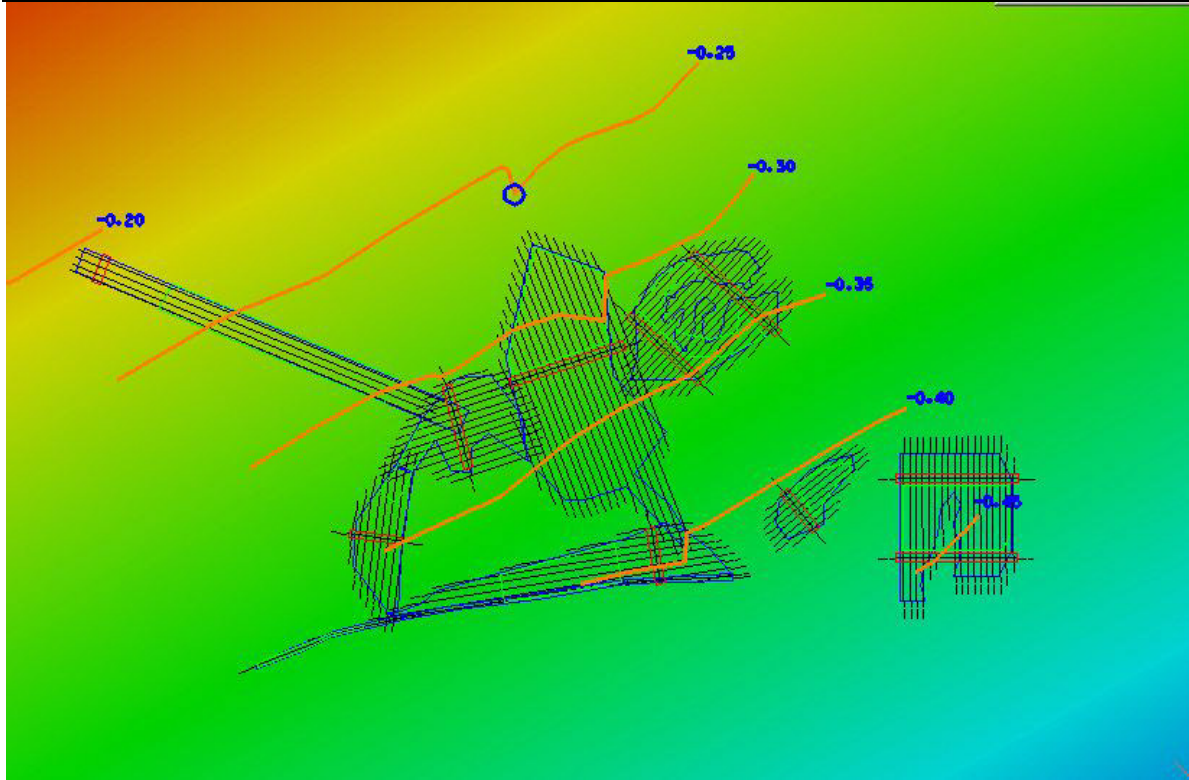

Hence, the supplied control points (to be used for geoid computation) have been derived using the NZgeoid05 and further adjusted using the above parameters to achieve Lyttelton 1937 heights.

This implies there is a perfect correlation between NZGeoid05 and the ellipsoidal/spirit leveled paired points.

2. DATA INSTALLATION

Data format : space delimited XYZ, XYZI and shp
Number & type of media : Two 4.7GB DVDs
Files on media : Data files, and README.PDF
Data formatted on : 13.06.2008
Disk volume : 11261B01NOP
AAMHatch Job Manager : Andrew Port +61 (0)7 3620 3107
Trevor King +61 (0)8 9228 6832

README FILE

This document (README.PDF) is provided as an Acrobat file in this volume.

To open the file, double click on the PDF file to activate Acrobat Reader Software.

Adobe Acrobat Reader may be downloaded from:

<http://www.adobe.com/products/acrobat/readstep2.html>

LOADING NOTES

Data may be copied using a file copy utility such as Windows Explorer or similar.

FILE SIZES AND NAMES

Data is provided in tiles 2km by 2km to the following file naming convention:

eg. CC25065714.grd CC - project abbreviation
 2506 - coordinate easting (in thousands) of south west tile corner
 5714 - coordinate northing (in thousands) of south west tile corner
 .grd - pulse returns, classified ASCII XYZ and XYZi format, as ground
 .non - pulse returns, classified ASCII XYZi format, as non-ground
 .shp - ESRI shape file

A list of the files contained on this volume is provided in Section 7.

SAMPLE DATA LISTING (thinned ground points – ASCII format)

ASCII xyz

E	N	RL
2460430.78	5711883.62	1.08
2460431.93	5711883.42	1.03
2460433.08	5711883.22	1.00
2460436.26	5711883.36	0.96
2460427.48	5711885.53	0.92
2460441.40	5711885.03	1.26
2460437.95	5711885.65	1.34
2460436.80	5711885.86	1.33
2460433.35	5711886.50	1.24 etc.

SAMPLE DATA LISTING (non thinned ground points – ASCII format)

ASCII xyzi

E	N	RL	Intensity
2452032.81	5703186.23	2.39	11798
2452032.48	5703187.34	2.43	12067
2452032.16	5703188.46	2.41	14616
2452031.82	5703189.60	2.38	13948
2452031.50	5703190.72	2.42	14619
2452031.16	5703191.85	2.33	15965
2452030.84	5703192.96	2.42	12878
2452030.53	5703194.10	2.56	12474
2452030.21	5703195.22	2.64	13413.

TRAJECTORY FORMAT – ASCII

ASCII xyz

Date	Time	E	N	H
6/02/2008	16:14:53	2472083.941	5746933.144	46.817
6/02/2008	16:14:54	2472083.941	5746933.147	46.821
6/02/2008	16:14:55	2472083.941	5746933.146	46.818
6/02/2008	16:14:56	2472083.941	5746933.149	46.83
6/02/2008	16:14:57	2472083.941	5746933.147	46.82
6/02/2008	16:14:58	2472083.941	5746933.147	46.814
6/02/2008	16:14:59	2472083.941	5746933.146	46.824

3. ADDITIONAL SERVICES

AAMHatch can perform the following additional services on the data contained on this volume if required:

- Change horizontal datum : to MGA or other local grid
- Alter geoid modeling : by transforming ALS data to fit orthometric survey heights
- Improve data classification : by tailoring parameters to suit regional variations
- Further classification : assist building identification by further classifying non-ground strikes
- Data thinning : to remove superfluous points not adding to the terrain definition
- Data subset : by dividing the data into different tiles or polygons
- Data presentation : by creating contours, profiles, perspectives, flythroughs, colour-coded height plots etc.
- Ground truthing : by comparing the ALS terrain model with extra independent height data
- Data gridding : to convert the measured spot heights into a regular grid
- Extra data : extra data was collected beyond that supplied on this volume
- Intensity Image : Supply an intensity (grayscale) image of the project area

Intensity image over project area.

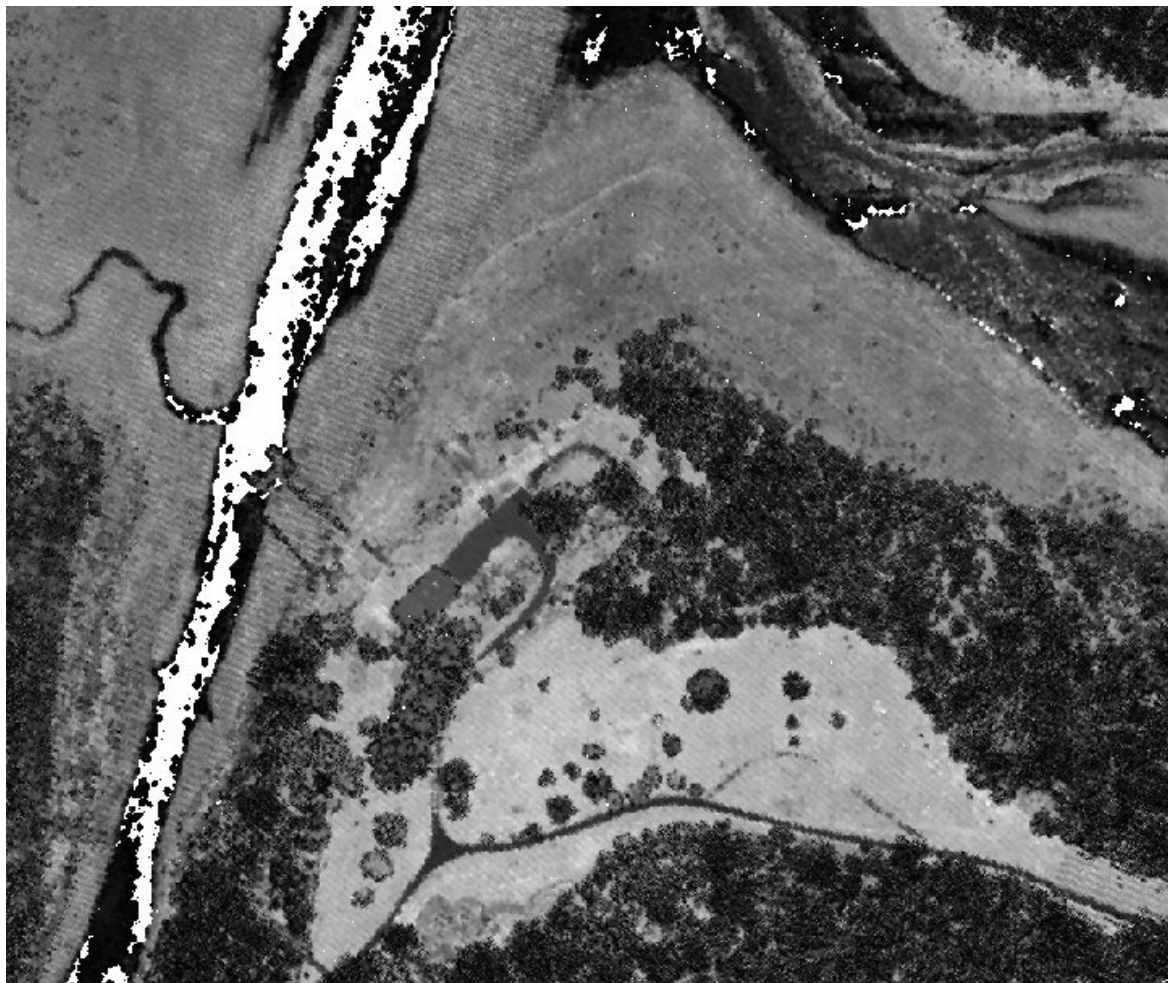

4. METADATA

DATA CHARACTERISTICS

Characteristic	Description
Format	Space delimited XYZ and XYZI
Size	345812100 data points (approx)
Captured terrain model	2.167 points pm ² estimated point density
Supplied terrain model (thinned)	Estimated ground point density of 0.15 pm ²
Laser return	Last and first pulse
Laser Intensity	Supplied on both first and last pulse returns
Laser footprint size	0.22m

REFERENCE SYSTEMS

Reference Point - GPS Primary Base Station		
	Horizontal	Vertical
Datum	WGS84	Ellipsoidal
Projection	UTM59	N/A
Geoid Model	N/A	
Reference Point	632397.06 E 5179450.15 N	45.693m
Datum	NZGD49	Lyttelton MSL 1937
Projection	NZMG	N/A
Geoid Model	N/A	NZGeoid05
Reference Point	2480777.70 E 5742302.50 N	33.88m

To adjust the LiDAR data to Lyttelton MSL 1937, a correction surface between NZGeoid05 and the Lyttelton MSL 1937 was derived from points supplied by Eliot Sinclair & Partners Limited surveying company (survey report 290335 21/05/2008, formatted data 02/06/2008).

SOURCE DATA

	Source	Description	Ref No	Date
Laser scanning	AAMHatch	25,000 Hz	11261B	06-11.02.2008
GPS base data	Eliot Sinclair & Partners Limited	Static GPS	Email supplied	02.06.2008
Base Stn coords	Eliot Sinclair & Partners Limited	Rapid static GPS	Email supplied	02.06.2008
Test points	Eliot Sinclair & Partners Limited	RTK GPS	Email supplied	02.06.2008
GPS Calibration Report	Eliot Sinclair & Partners Limited	GPS Calibration report	N/A	20.05.2008
Survey Report	Eliot Sinclair & Partners Limited	Survey report for Lidar Capture – Ellesmere, Canterbury	290335	21.05.2008

EXPECTED ACCURACY

Project specifications and technical processes were designed to achieve data accuracies as follows:

	Measured Point	Derived Point	Basis of Estimation
Vertical data		0.15m	Project design
Horizontal data	<0.45m		System specifications ($1/3500$ flying height)
Test points	0.05m		Survey methodology used

Notes On Expected Accuracy

- Values shown represent standard error (68% confidence level or 1 sigma), in metres.
- “Derived points” are those interpolated from a terrain model.
- “Measured points” are those observed directly.
- Accuracy estimates for terrain modelling refer to the terrain definition on clear ground. Ground definition in vegetated terrain may contain localised areas with systematic errors or outliers which fall outside this accuracy estimate.
- The definition of the ground may be less accurate in isolated pockets of dissimilar terrain/vegetation combinations.

LIMITATIONS OF DATA

- The definition of the ground under trees may be less accurate.

DATA VALIDATION**Test points comparison against ellipsoidal heights**

LiDAR data was initially compared to over 6000 test points defined in WGS84/UTM 59. The field test points were obtained by a variety of field survey methods and assumed to be error free. The test points were distributed throughout the project area, located on clear ground, with the majority located on sealed roads. Comparison of the test points with elevations interpolated from measured data resulted in:

Mean difference : 0.043m
 St. Deviation : 0.078m
 Standard Error (RMS): 0.089m

Test points comparison against Lyttelton 1937 heights

LiDAR data was then converted to the NZMG datum and the vertical heights were compared and adjusted to test points as supplied by Eliot Sinclair Pty Ltd. in NZMG, Lyttelton 1937 datum. Comparison of the test points with elevations interpolated from measured data resulted in:

Mean difference : 0.072m
 St. Deviation : 0.072m
 Standard Error (RMS): 0.005m

- Data classification has been manually checked and edited against ALS intensity imagery.

USE OF DATA

- Intended use : Preliminary Design subject to final survey

5. CONDITIONS OF SUPPLY

The data in this volume is provided by AAMHatch Pty Limited (AAMHatch) to **Christchurch City Council** under the client's Terms of Engagement, which allow **Christchurch City Council** to assume shared ownership with AAMHatch, in accord with documented provisions, and subject to the following conditions:

1. This file (README.PDF) is always stored with the unaltered data contained in this volume.
2. The data is not altered in any way without the approval of AAMHatch. The data may be copied from this file to another.
3. The data is not used for purposes beyond that explicitly agreed in the description of the Services provided by AAMHatch.

Any breach of these conditions will result in the immediate termination of the license issued by AAMHatch, and **Christchurch City Council** will indemnify AAMHatch from all resulting liabilities.

Any problems associated with the information in the data files contained in this volume should be reported to:

AAMHatch Pty Limited

152 Wharf St,
BRISBANE QLD 4000
Telephone (07) 3620 3111
Facsimile (07) 3620 3133
Email info@aamhatch.com
Web www.aamhatch.com

6. VALIDATION PLOTS

Christchurch City Council tile layout showing shaded model

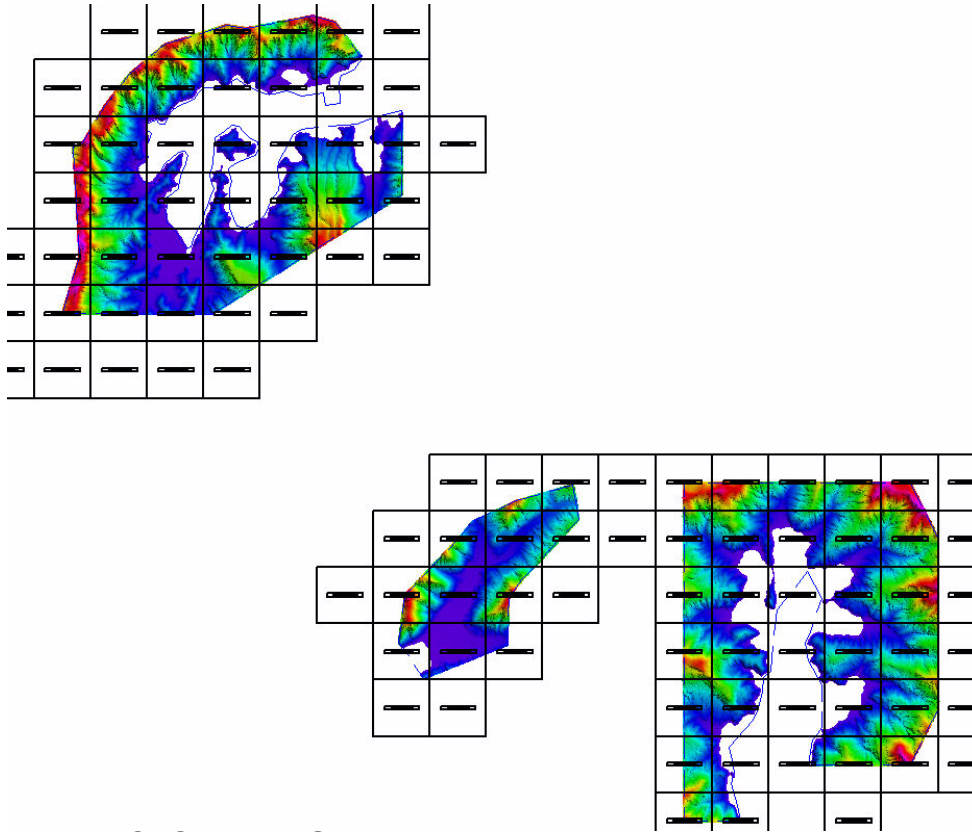

TRAJECTORY (FLIGHT4)

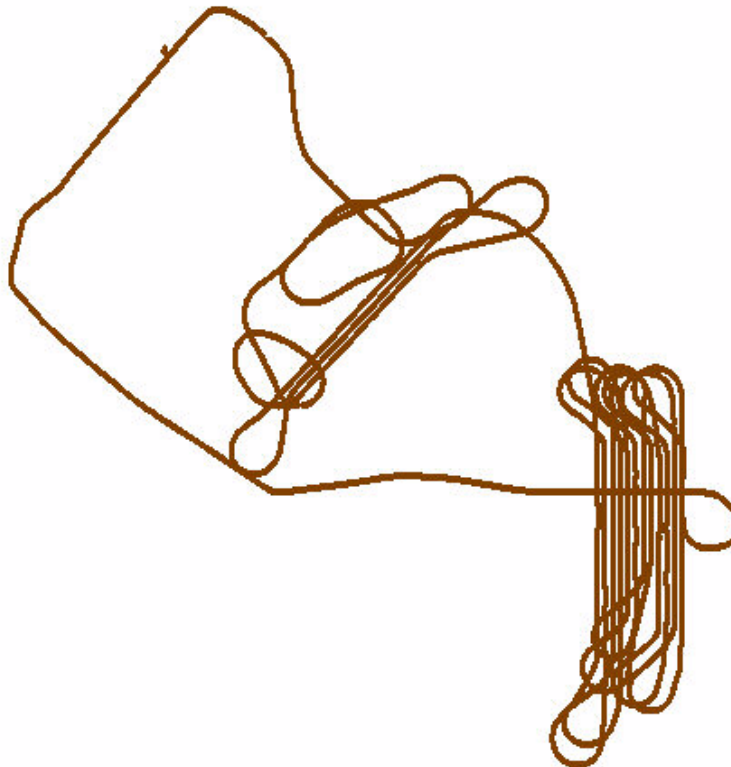

7. FILES SUPPLIED

Readme

This file.

Metadata

Tile Layout

13/06/2008 8:14 am 200 KB 11261B_ProjectExtentsNZGM.dxf

Geoid Model

12/06/2008 1:06 am 136445 KB Geoid_Model_NZMG.dxf

File Listing

13/06/2008 12:15 pm 69 KB 11261B01NOP_Complete_File_List.pdf

XYZ and XYZ I

Ground (.grd) and Non-Ground points (.non)

See 11261B01NOP_Complete_File_List.pdf for complete file listing

Date Time Stamped Trajectories

ASCII and .shp

See 11261B01NOP_Complete_File_List.pdf for complete file listing

Directory Structure

